

## Gas Discharge Tube Lightning Arrestor N Connectors and a Replaceable Protective Element



**Features:**

- ✦ Frequency to 3.2 GHz Excellent RF Performance
- ✦ Multiple Strike Capability
- ✦ 50 kA Surge Protection
- ✦ Bi-directional Protection
- ✦ Rugged and Waterproof
- ✦ High RF Power and Low PIM

*PTRONMONFxxS (N-Male to N-Female)*

### RF Specifications

- ✦ Nominal Impedance – 50 Ω

Frequency (GHz)	VSWR	Insertion Loss (dB)
dc – 2.5	1.15 Max	0.10 Max
2.5 – 3.0	1.20 Max	0.15 Max
3.0 – 3.2	1.35 Typ	0.25 Typ

- ✦ Through Current: 65V/10A Max
- ✦ RF Power: See Protection Voltage table
- ✦ PIM3: -116 dBc  
(2X43 dBm 1.9 GHz tones)

### Transient Specifications

*(1.2X50µs Voltage / 8X20µs Current waveform)*

- ✦ Maximum Transient: 50 kA
- ✦ Multiple Strike: 20 kA 10 times
- ✦ Let-through: See Protection Voltage table
- ✦ Replaceable Gas Discharge Tube 90V to 1000V

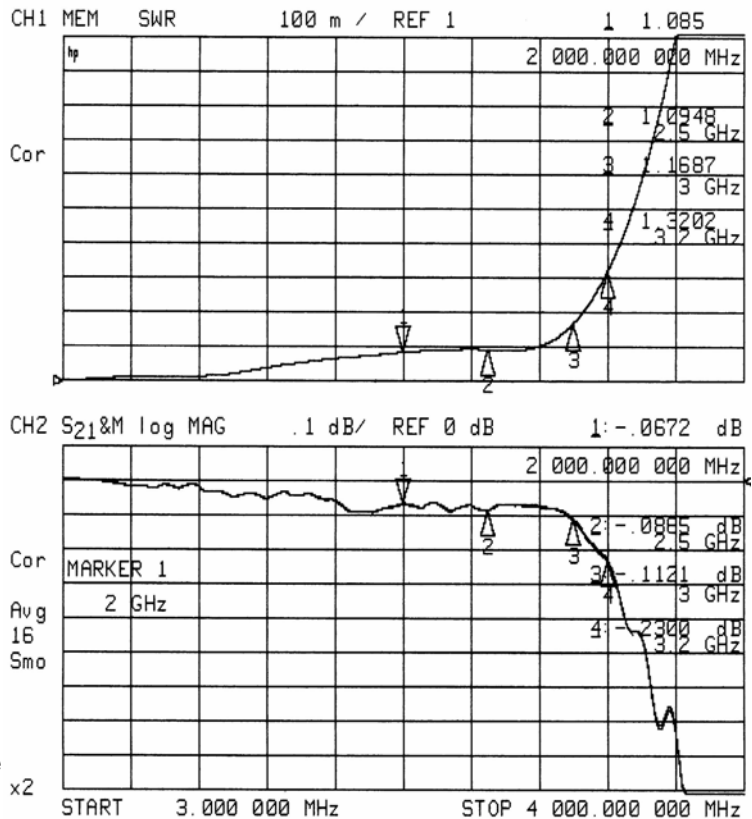

**Typical VSWR and Insertion Loss**

### Mechanical Specifications

✦ Weight 0.28 pounds typ/125 g typ

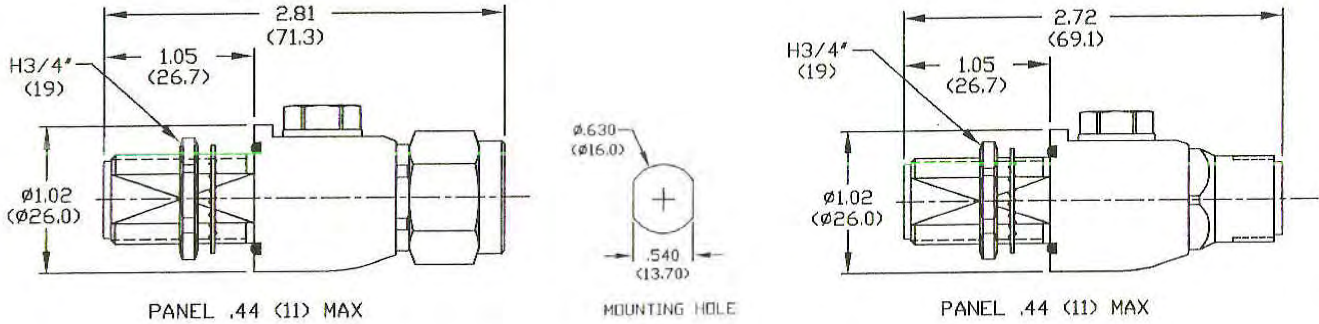

### Environmental Specifications

<b>Temperature Range</b>	-40°C to +90°C
<b>Salt Fog</b>	MIL-STD-202 Method 101D / Condition B (35°C/96 hrs)
<b>Immersion</b>	MIL-STD-202 Method 104A / Condition A (65°C to 25°C w/NaCl – 2
<b>Moisture Resistance</b>	MIL-STD-202 Method 106E (65 °C/98% RH condensing/240 hrs)
<b>Temperature Shock</b>	MIL-STD-202 Method 107D / Condition B-1 (25 cycles -65°C to +125°C)
<b>Life (Elevated Temperature)</b>	MIL-STD-202 Method 108A / Condition A (96 hours at 100°C)
<b>Dust and Waterproof Rating</b>	IEC529 IP68 (dust-tight and water proof 24 hrs / 1 m)
<b>Vibration</b>	MIL-STD-202 Method 204D / Condition D (10Hz-2kHz 0.06"DA/20g)
<b>Mechanical Shock</b>	MIL-STD-202 Method 213 / Condition A (50g/11ms ~24")

### Material and Finish

Component	Material	Finish
Outer Parts	Brass	Guardplate™
Center Contact	BeCu	Gold
Insulator	PTFE	-
Gasket	Si Rubber	-

Guardplate™ is an alloy finish with the PIM and conductivity of Silver and the durability and anti-tarnish properties of Nickel.

- 1 Use the voltage code in the part number
- 2 For multiple carriers, sum of peak voltages should not exceed 60% of the protection voltage
- 3 Input is 6kV @ 1.2x50µs/ 3kA @ 8x20µs.

### Protection Voltage

Protection Voltage	Voltage Code <sup>1</sup>	RF Power (W) <sup>2</sup>	Let-through (V <sub>pk</sub> / mJ) <sup>3</sup>
90	09	37	600 / 0.3
150	15	95	600 / 0.3
230	23	240	650 / 0.5
350	35	550	800 / 0.7
470	47	1000	1200 / 2.2
600	60	1600	1500 / 4.4
800	80	2900	1900 / 9.0
1000	99	4500	2200 / 14

### Part Number

PTR ONXONF XX S

